

Precision Sliding Short Circuit

GERLING

Model GA1206A
Model GA1207A

GAE's family of Precision Sliding Short Circuits are designed for use in high power microwave networks to establish a standing wave in waveguide and continuously vary the location of the standing wave throughout a range of positions. Typical uses include waveguide applicators in which a standing wave must be accurately positioned to maximize the coupling of microwave power to the load being heating.

The sliding plunger utilizes a non-contacting cavity type 1/4-wave reactive choke design which allows adjustment under high power operation without high losses or arcing. High temperature, low loss polyimide "buttons" provide low friction surfaces for reduced wear. Positional accuracy is provided by a precision screw drive mechanism. Precise positioning is enabled by a multi-turn dial with a digital readout calibrated in tenths of a turns unit.

General Specifications:

Frequency	2450 MHz nominal
Power (continuous)	6 kW
Waveguide	GA1206A: WR340 (RG113/U) GA1207A: WR430 (RG105/U)
Input Flange	GA1206A: UG554/U GA1207A: UG437B/U
Plunger Travel	GA1206A: 4.0 inches (10 cm) GA1207A: 3.5 inches (8.9 cm)
Position Indicator	Multi-turn dial with digital readout
Readout Calibration	0.008 inches (0.02 cm) movement per unit on the digital readout
Backlash	0.015 inches (0.04 cm) max.
Return Loss	0.05 dB max @ 2450 MHz

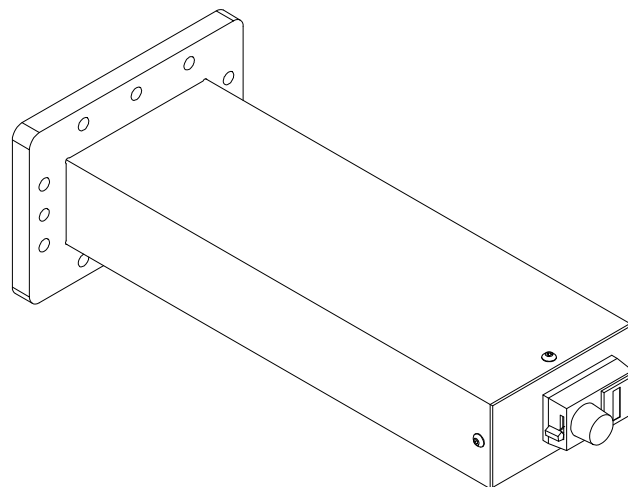

Model GA1206A

Options:

- ◆ Heli-Coils or studs on flanges (any combination)
- ◆ Round flange with taper for quick-disconnect clamp on WR340
- ◆ Flange interlock switches

Accessories:

- ◆ Flange Hardware Kit, Model GA8409 (please see GA8409 specification for selection)

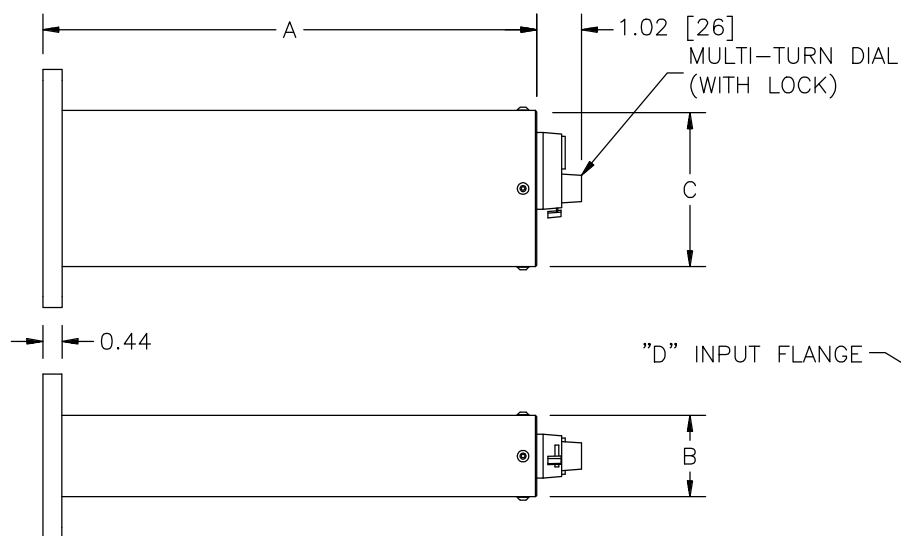

	GA1206A	GA1207A
WAVEGUIDE	WR340	WR430
A	11.25 [286]	10.00 [254]
B	1.86 [47.2]	2.31 [58.7]
C	3.56 [90.4]	4.46 [113]
D	UG554/U (CPR)	UG437A/U (CPR)

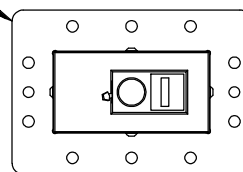

**GERLING APPLIED
ENGINEERING, INC.**

© 2005-2008 Gerling Applied Engineering, Inc.
PO Box 580816 • Modesto, CA 95358 • USA
Phone: +1-209-527-8960 • Fax: +1-209-527-5385
E-mail: sales@2450MHz.com • Web: www.2450MHz.com