

Precision High Power E-H Tuner, WR284

GERLING

Model GA1018

GAE's family of precision high power E-H tuners are designed for load impedance matching in high power microwave heating systems. These E-H tuners are particularly useful under conditions of combined high power and high VSWR in which conventional stub tuners are more likely to cause voltage breakdown and arcing. The non-contacting sliding plungers of the E-H tuner employ a 1/4-wave choke structure allowing adjustment while under high power operation. The plunger is adjusted by a precision screw assembly which allows ultra-fine tuning and minimizes backlash. A multi-turn dial with digital readout enables precise repeatable positioning. The simple yet rugged design of the E-H tuner makes them ideal for a variety of laboratory, production and OEM applications.

Model GA1018 features the popular WR284 Q-D (quick-disconnect) round flange that uses the convenient single screw clamp (model GA8410) for waveguide connections.

General Specifications:

Waveguide	WR284
Flange	UG584/U with taper
Frequency	2450 MHz +/- 50 MHz
Plunger Travel	4.7 inches (11.9 cm)
Power (continuous)	3 kW
Construction	Dip brazed aluminum waveguide
Finish	Chemical conversion coating on waveguide, Black textured paint

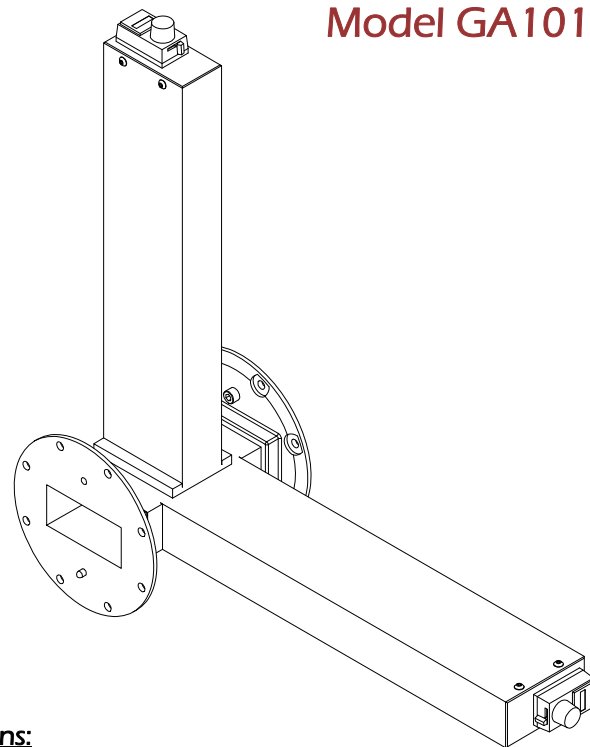

Options:

- ◆ Flange interlock switches

Accessories:

- ◆ GA8410 quick-release flange clamp

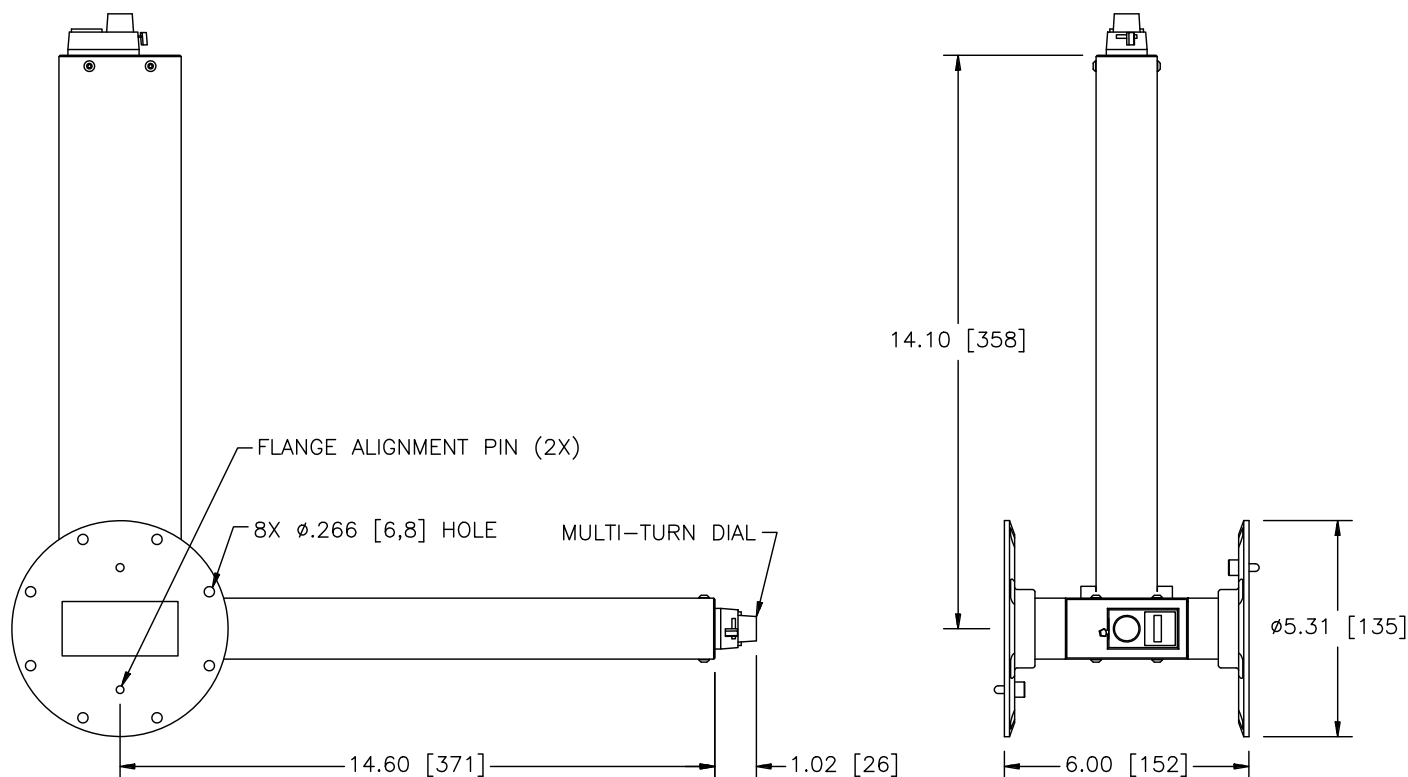

GERLING APPLIED
ENGINEERING, INC.

All dimensions are in inches [millimeters].

© 2005-2012 Gerling Applied Engineering, Inc.
PO Box 580816 • Modesto, CA 95358 • USA
Phone: +1-209-527-8960 • Fax: +1-209-527-5385
E-mail: sales@2450MHz.com • Web: www.2450MHz.com

Updated 13JUN12