

Waveguide Taper Transition, WR284 to WR340/WR430

GERLING

Model GA2003
Model GA2004

GAE offers a series of high power tapered waveguide transitions that deliver high performance at high power levels. Each model in the series is designed using a theoretically optimal taper length to achieve near perfect waveguide transitioning.

The model GA2003 transitions between WR284 and WR340 waveguide while the GA2004 transitions between WR284 and WR430. Both models feature the popular WR284 Q-D (quick-disconnect) round flange that uses a single screw clamp for waveguide connections.

General Specifications:

Frequency	2450 MHz +/- 30 MHz
Input Power	6 kW continuous max.
Port 1 Flange	WR284 Q-D (UG584/U equiv.)
Port 2 Flange	GA2003: WR340 (UG554/U) GA2004: WR430 (UG437B/U)
Input VSWR	1.05 max.
Insertion Loss	.02 dB max
Material	6061-T6 aluminum
Construction	Dip braze per MIL-B-7883C, Type 5, Grade B
Finish	Clear chemical film per MIL-C-5541, Class 1A

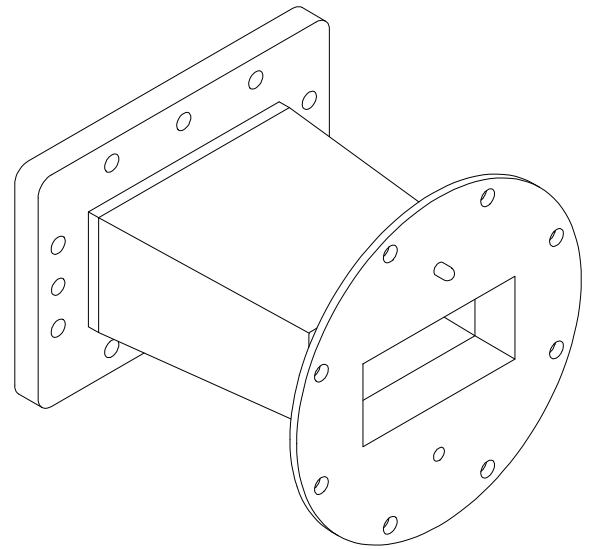

Model GA2003

Options:

- ◆ Threaded inserts or studs on WR340 or WR430 flange (any combination)
- ◆ Flange interlock switch
- ◆ Alternate finish

ALL FLANGE BOLT HOLES ϕ .265 [6,7] (TAPPED HOLES OPTIONAL).

	GA2003	GA2004
A	5.16 [131]	4.72 [120]
B	3.75 [95,3]	4.19 [106,4]
C	5.44 [138,2]	6.34 [161,0]
D	WR340 (UG554/U)	WR430 (UG437B/U)

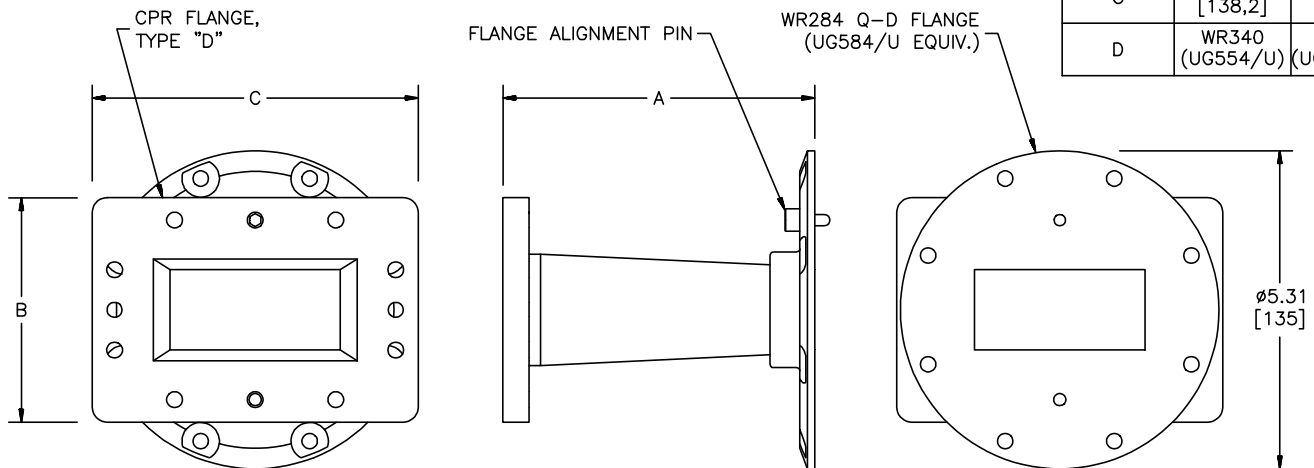

**GERLING APPLIED
ENGINEERING, INC.**

© 2003 Gerling Applied Engineering, Inc.
PO Box 580816 • Modesto, CA 95358 • USA
Phone: +1-209-527-8960 • Fax: +1-209-527-5385
E-mail: sales@2450MHz.com • Web: www.2450MHz.com