

90° H-Plane Bend, CPR284

GERLING

Model GA2303

Specifications:

Waveguide:	WR284
Flange:	CPR284F
Material:	6061-T6 Aluminum
Construction:	Dip braze per MIL-B-7883, Type V, Class B
Finish:	Clear chemical film per MIL-DTL-554 1F, Type II, Class 3
VSWR:	1.10 (max.)
Insertion Loss:	.02 dB (max.)
Length A/B Min, Max:	2.12 (53,9); 48.00 (1219)

Ordering Information:

Model Number Format: **GA2303** = Standard model with 4" lengths (dimensions "A" and "B")

GA2303-Y.YY-Z.ZZ

Y.YY = "A" flange dimension (inches)

Z.ZZ = "B" flange dimension (inches)

Optional Threaded Inserts: Add "H" or "M" after dimension suffix where inserts are desired
(H = 1/4-20 UNC; M = M6 metric)

Example: **GA2303-3.00-4.50H** designates a 90° H-plane Bend, CPR284, with thru holes at 3.00" flange and 1/4-20 UNC inserts at 4.50" flange

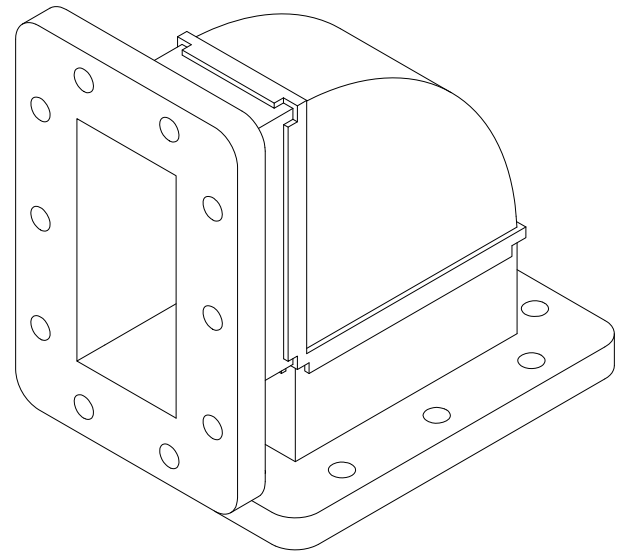

Options:

- ◆ Threaded studs (SAE or metric)
- ◆ Flange interlock switches
- ◆ Alternate finish (paint)
- ◆ Alternate materials (brass, copper)

Accessories:

- ◆ Flange hardware kit, model GA8409 (please specify type and length)
- ◆ Flange bolt interlock, model GA8408

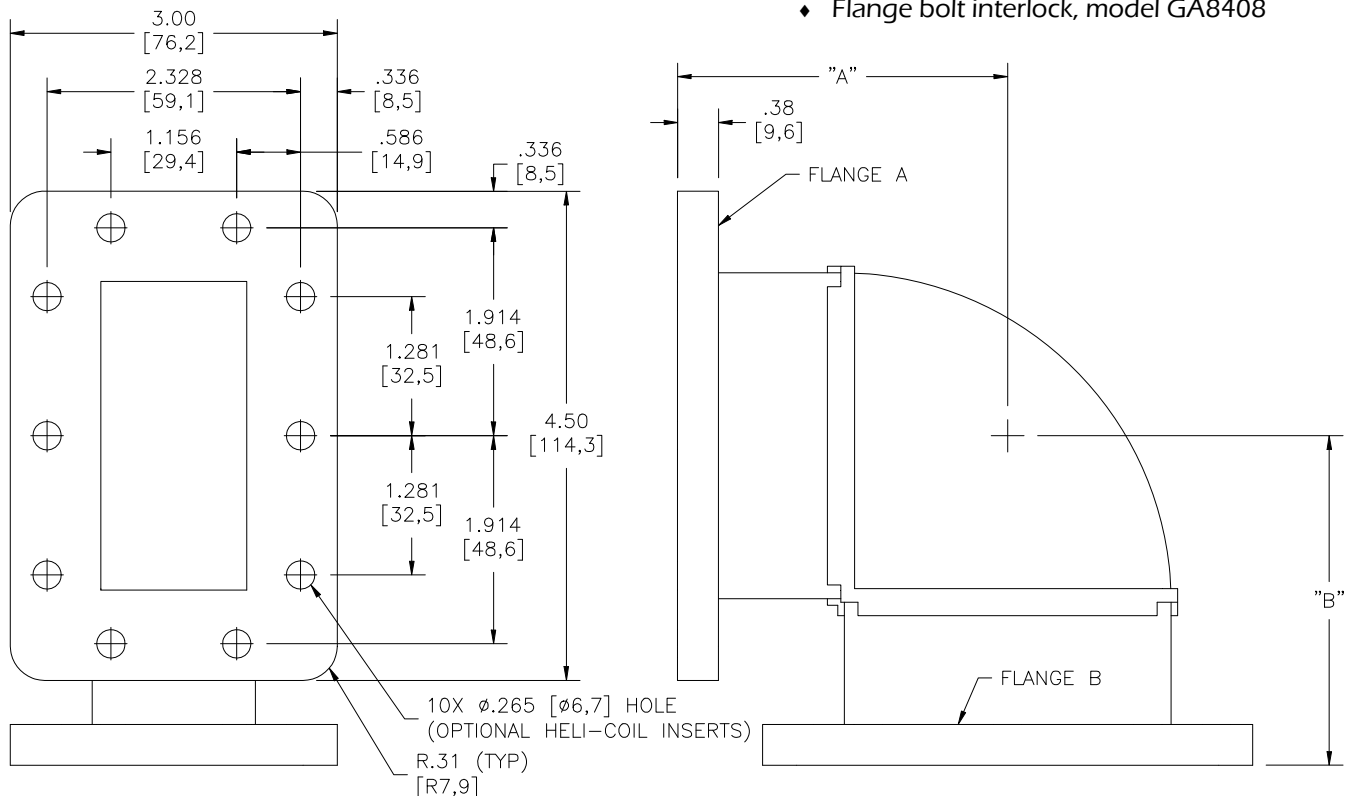

GERLING APPLIED
ENGINEERING, INC.

© 2003-2008 Gerling Applied Engineering, Inc.
PO Box 580816 • Modesto, CA 95358 • USA
Phone: +1-209-527-8960 • Fax: +1-209-527-5385
E-mail: sales@2450MHz.com • Web: www.2450MHz.com