

# Coupler Power Interface

GERLING

## Model GA3301

The Coupler Power Interface (CPI) is a convenient means for measuring the microwave signal level at the output port of most common waveguide power couplers. The microwave signal from the waveguide coupler is converted to a DC voltage that is proportional to waveguide power. Factory calibrated of the output signal for a desired full scale operating range may be specified by the user. Standard calibration is 10 mW full scale.

The input power supply requirement is +24 VDC. Connection of the input supply and output signal is to a 9-pin male subminiature "D" connector. The compact enclosure is die-cast aluminum and can be conveniently mounted directly to the waveguide coupler output port.

### Specifications:

Frequency	100 kHz - 2.5 GHz
Input Signal	1 uW minimum, 100 mW peak maximum
Output Signal	0-10 VDC proportional to waveguide power (calibrated for specific input waveform)
Calibration Range	Up to 10 mW full scale input
Accuracy & Linearity	1 mW Scale: +/- 3% FS at 25 °C 10 mW Scale: +/- 5% FS at 25 °C
Precision	+/- 5% within +10-40 °C
Supply Voltage	+24 VDC, 50 mA max.
Input Connector	Type N male
Output Connector	9-pin male subminiature "D"
Construction	Aluminum enclosure

### Ordering Information:

Model Number Format:	<b>GA3301-X.X</b> X.X = Full scale input range in milliwatts (default = 2.0 mW)
Optional 9-pin "D" cable:	3m length: GAE part no. 071401-09 2m length: GAE part no. 071402-09

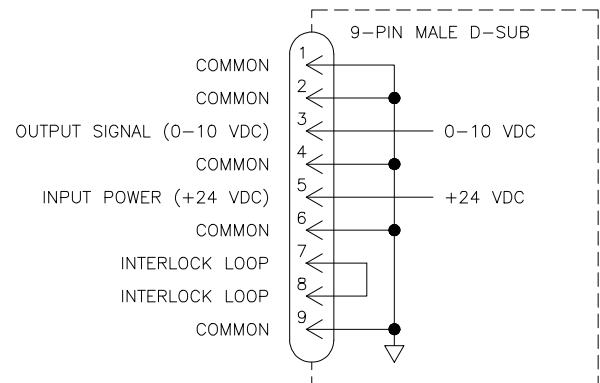
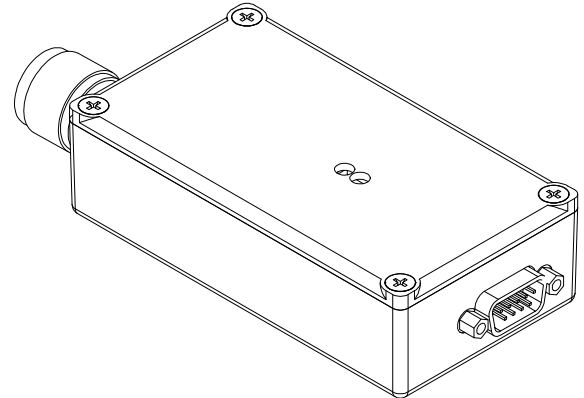

DC Output Connector

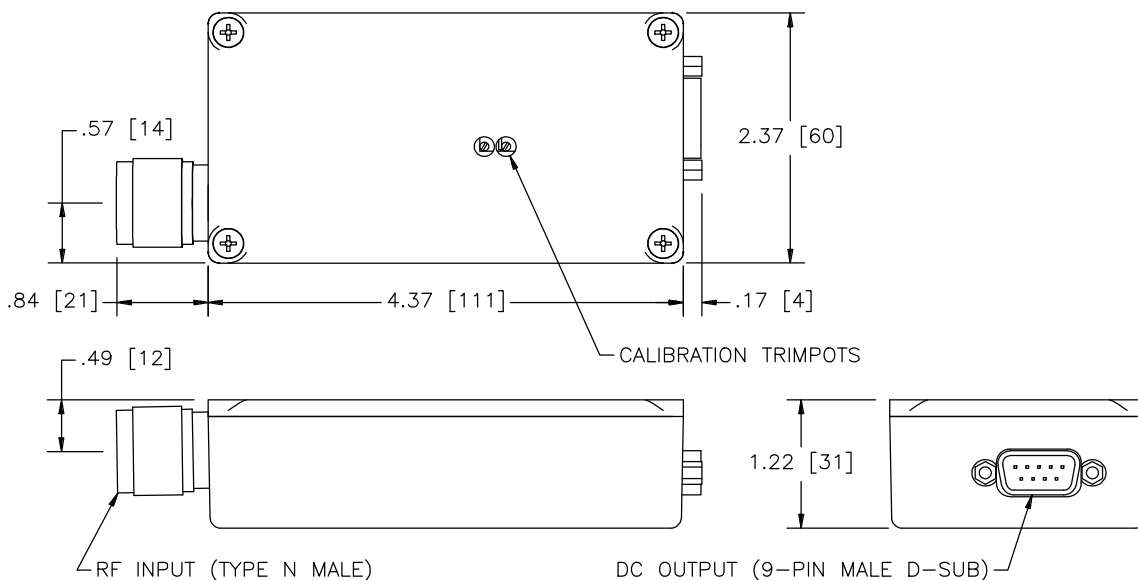

GERLING APPLIED  
ENGINEERING, INC.

© 2003 Gerling Applied Engineering, Inc.  
PO Box 580816 • Modesto, CA 95358 • USA  
Phone: +1-209-527-8960 • Fax: +1-209-527-5385  
E-mail: sales@2450MHz.com • Web: www.2450MHz.com