

Arc Detect Module

GERLING

Model GA8414

The GA8414 Arc Detect Module (ADM) is designed to detect an arc discharge occurring inside a waveguide or process cavity due to high electric field strength. A photo transistor views through the threaded mounting bushing into the waveguide or cavity and detects arcs occurring within its line of sight. The ADM can also be used for non-fault applications such as the detection of a plasma or combustion. The module can be easily mounted by attaching to an appropriately located threaded boss or panel (cavity wall) hole.

Output signals include an open-collector transistor driver and SPDT form C (NO/NC) dry relay contacts. Upon detecting an arc, the outputs change state momentarily (non-latching) in the standard configuration, or permanently in the optional "latching" configuration. Options include compatibility with pressurized waveguide, a sealed enclosure and wide angle viewing.

Many GAE waveguide components are available with a custom mounting port for the GA8414 detector module. Contact GAE for advice and detailed information on mounting the GA8414.

General Specifications:

Supply Voltage	15-24 VDC (Vcc), 50 mA plus output driver current
Output Signal	Open-collector Darlington transistor, 500 mA max drain current (input voltage = Vcc)
Output Relay	SPDT Form C (NO/NC) dry contacts, 30 V AC/DC max, 2 A max resistive load (1 A max inductive load)
Response Time	5 ms max.
Output Type	Standard: Momentary (non-latching) Optional: Latching
Output Duration	480 ms (non-latching)

Options:

- ◆ Pressure compatible (30 psi max)
- ◆ Sealed enclosure
- ◆ Wide angle viewing

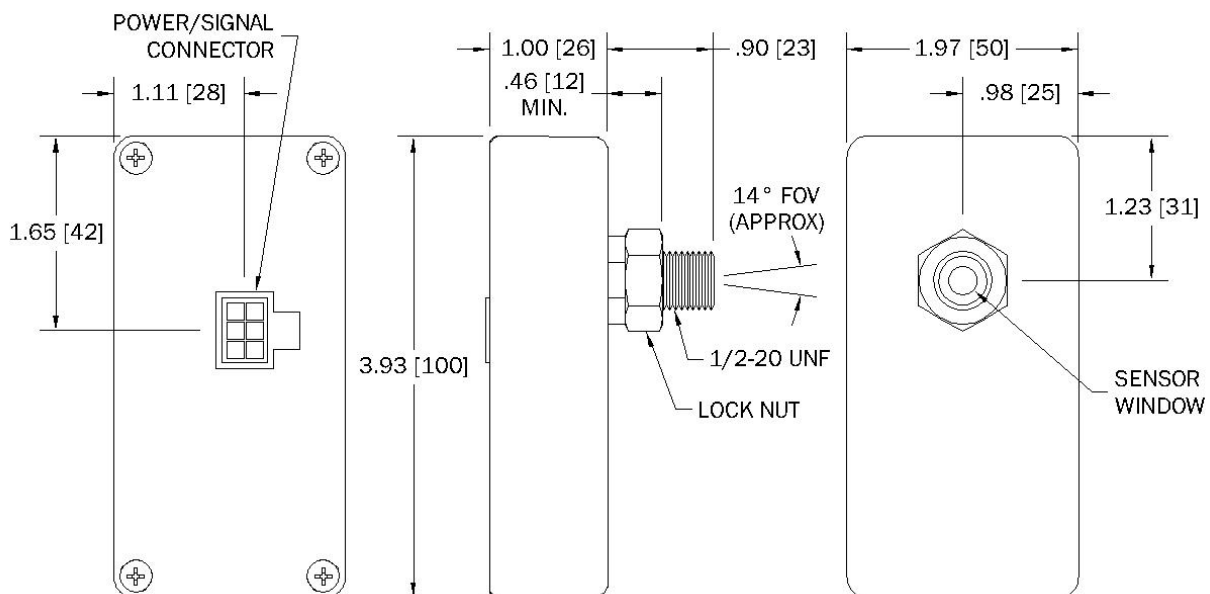
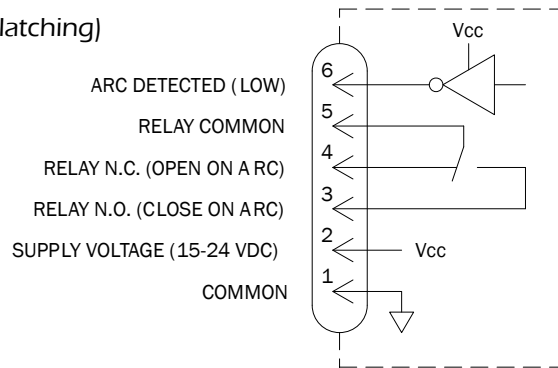
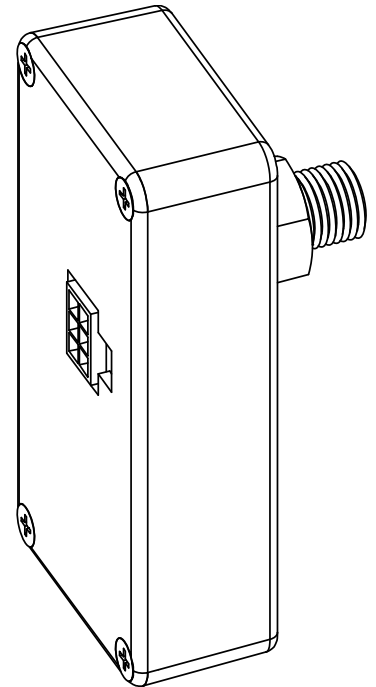

GERLING APPLIED
ENGINEERING, INC.

© 2013 Gerling Applied Engineering, Inc.
PO Box 580816 • Modesto, CA 95358 • USA
Phone: +1-209-527-8960 • Fax: +1-209-527-5385
E-mail: sales@2450MHz.com • Web: www.2450MHz.com